

半 柵

内 径 (mm)	寸 法 (mm)					重 量 (kg)	単 価		メ モ
	A	B	C	D	E		工場渡	配 達	
240	345	200	27	160	55				
300	410	200	30	160	55				
360	480	200	35	200	70				
450	580	200	40						
600	750	200	50						

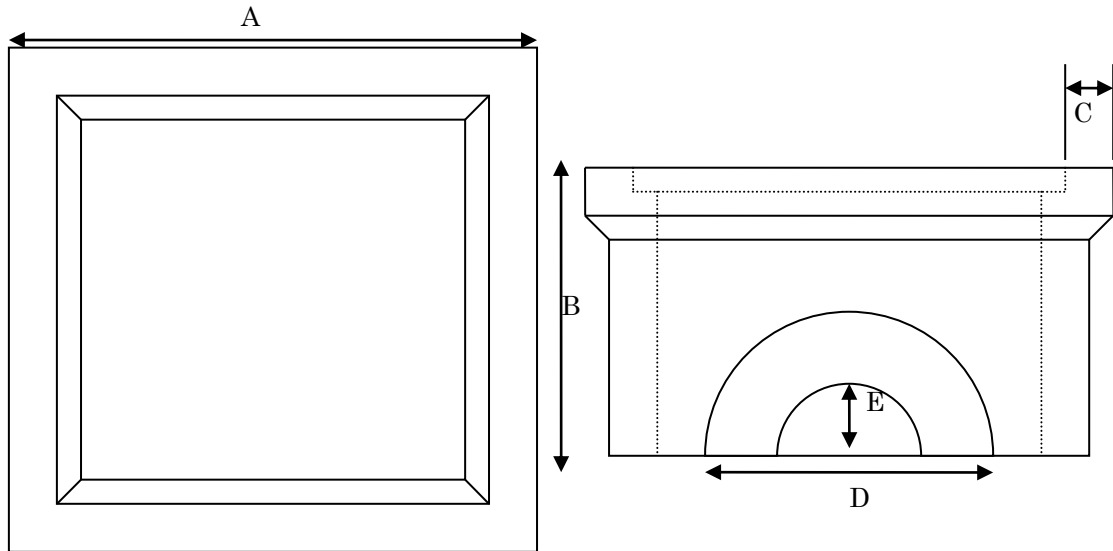

蓋

蓋	A	B
240	265	33
300	325	35
360	385	40
450	485	45
600	635	60

