

# 溜 柵

内 径 (mm)	寸 法 (mm)					重 量 (kg)	単 価		メ モ
	A	B	C	D	E		工場渡	配 達	
240	345	370	27	160	110	35			
300	410	430	30	160	110	43			
360	480	490	35	200	140	61			
450	580	600	40	240	170	99			
600	750	770	50	330	250	179			

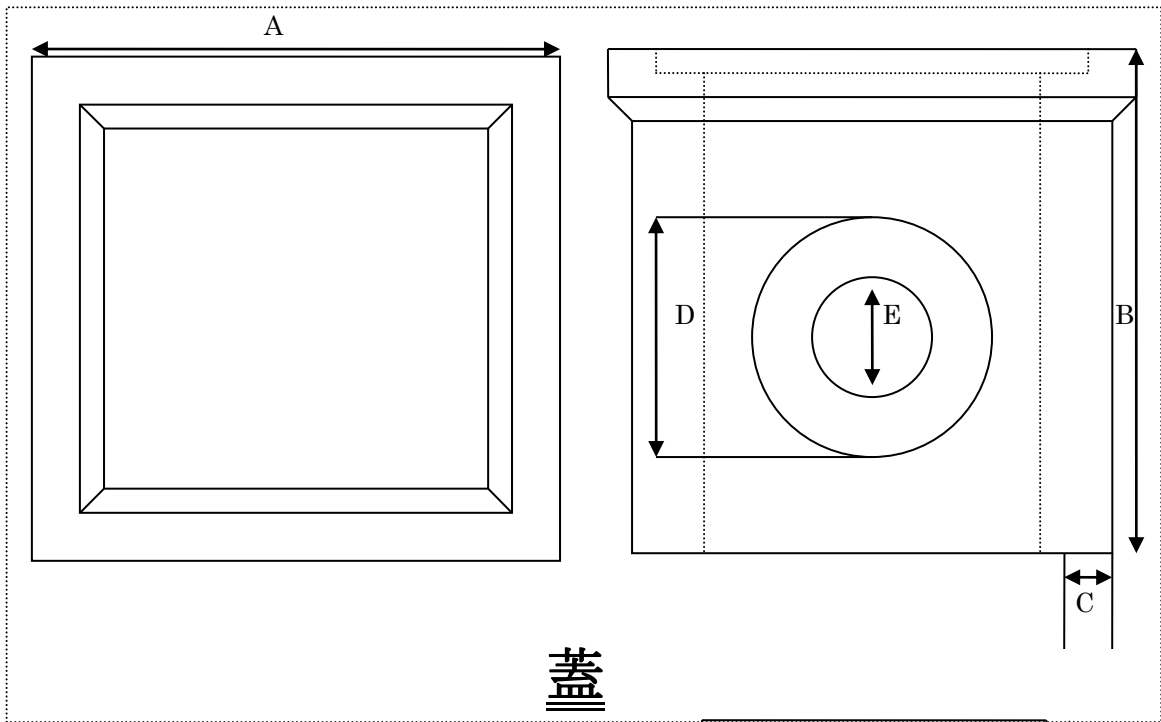

## 蓋

蓋	A	B
240	265	32
300	325	34
360	385	40
450	485	45
600	630	60

